

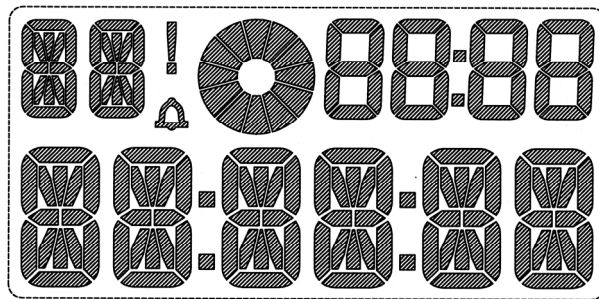

SynchroChron LCD

User's Guide



Revision: 1.16
Date: 8/20/2007 13:32
Author: CC Cox
ID: SCLCD-USR-1.16
URL: <http://synchro.com/downloads/SCLCD-USR.pdf>

Copyright © 2006-2007 SynchroSystems Inc
"SynchroSystems" is a registered service mark of SynchroSystems Inc.
"SynchroChron" and the triple-S logo are trademarks of SynchroSystems Inc.
Uniglo is a trademark of Lumitex Inc.

Description

The SynchroChron Liquid Crystal Display (LCD) is a 44-pin 160-segment multiplexed alphanumeric display designed for use in timing applications. The low drive voltage is suited for battery-powered devices. It is compatible with the integrated LCD controller in Texas Instruments' MSP430x4xx family of low-power microcontrollers. The transreflective back layer allows for operation in a wide range of lighting conditions, with or without a backlight.

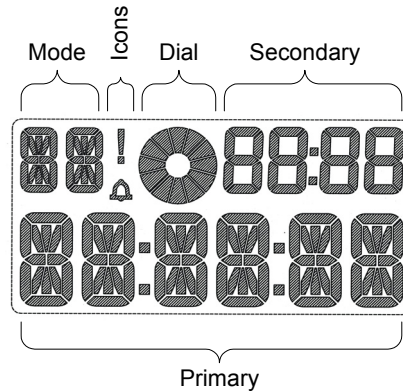

Figure 1 - Display Areas

Primary Display Area

The primary (lower) display area consists of 6 14-segment alphanumeric characters. The characters are grouped in pairs and separated by two punctuation marks. Each character is 10 mm tall and can be used to display most ASCII characters. Each punctuation mark consists of two dots which can be combined to display a decimal point, dash or colon. This area can display time and date information as well as short text messages.

Secondary Display Area

The upper right display area consists of 4 7-segment numeric digits. The digits are grouped in pairs and separated by a punctuation mark. Each digit is 7 mm tall. The punctuation mark consists of two dots which can be combined to display a decimal point, dash or colon. This area can be used to provide secondary time or date information.

Mode Display Area

The upper left display area consists of 2 14-segment alphanumeric characters. Each character is 7 mm tall and can be used to display most ASCII characters. This area can be used to indicate the mode or status.

Dial

The dial in the upper center of the display consists of 12 independently addressable hands. The dial can be used to provide a graphical, animated time or bar-graph representation.

Icons

Located between the dial and the mode, two icons are available for use as status indicators. The exclamation mark can be used to indicate an alarm or unusual condition. The bell icon can be used to indicate chime or reminder status.

Backlight

An optional fiber-optic LED backlight panel is available. The high-intensity T1¼ (5mm) LED can be used in 3V systems without a voltage booster. The thin woven-fiber Lumitex UniGlo backlight panel provides efficient and even distribution of the LED light.

Specifications

LCD

Segments	160
Display Type	Positive Twisted Nematic (TN)
Viewing Angle	6 o'clock
Front Polarizer	Transmissive
Back Polarizer	Transflective
Drive Voltage	2.8 - 3.2 Volts
Drive Duty Cycle	1/4
Drive Bias	1/3
Connector	44 through-hole pins
Pin pitch	2 mm
Pin length	20 mm
Operating Temperature	-20 to +50 °C
Storage Temperature	-30 to +60 °C

Backlight

Typical Illuminance (at panel surface)	245 lux @ 30 mA
	135 lux @ 20 mA
Typical Illuminance (at LCD surface)	44 lux @ 30 mA
	29 lux @ 20 mA
Dominant Wavelength	630 nm @ 20 mA (red-orange)
Maximum Forward Voltage	2.8 V @ 20 mA
Maximum Continuous Forward Current	30 mA
Peak Forward Current	150 mA
Maximum Power Dissipation	120 mW
Operating/Storage Temperature	-40 to +85 °C

Segments

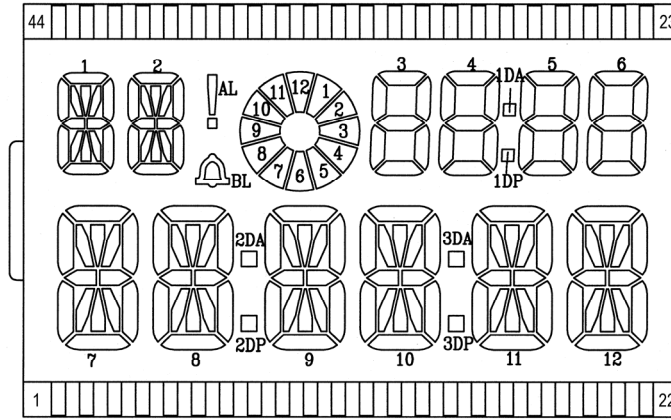

Figure 2 - Pin & Segment Designations



Figure 3 - Character Segment Designations

Table 1 - Pin Functions

Pin		Segments			
Number	Name	COM0	COM1	COM2	COM3
1	S0	7E	7Q	7G	7F
2	S1	7D	7P	7J	7H
3	S2	7N	7M	7K	7A
4	S3	8E	7C	8F	7B
5	S4	8D	8Q	8G	8H
6	S5	8N	8P	8J	8A
7	S6	8C	8M	8K	8B
8	S7	9E	9Q	9G	9F
9	S8	9D	9P	9J	9H
10	S9	9N	9M	9K	9A
11	S10	10E	9C	10F	9B
12	S11	10D	10Q	10G	10H
13	S12	10N	10P	10J	10A
14	S13	10C	10M	10K	10B
15	S14	3DP	3DA	2DP	2DA
16	S15	11E	11Q	11G	11F
17	S16	11D	11P	11J	11H
18	S17	11N	11M	11K	11A
19	S18	12E	11C	12F	11B
20	S19	12D	12Q	12G	12H
21	S20	12N	12P	12J	12A
22	S21	12C	12M	12K	12B

Pin		Segments			
Number	Name	COM0	COM1	COM2	COM3
23	S22	6A	6B	6C	6D
24	S23	6F	6G	6E	1DP
25	S24	5A	5B	5C	5D
26	S25	5F	5G	5E	1DA
27	S26	4A	4B	4C	4D
28	S27	4F	4G	4E	5
29	S28	3A	3B	3C	3D
30	S29	3F	3G	3E	4
31	S30	12	1	2	3
32	S31	11	10	9	8
33	S32	AL	BL	6	7
34	S33	2B	2K	2M	2C
35	S34	2A	2J	2P	2N
36	S35	2H	2G	2Q	2D
37	S36	1B	2F	1C	2E
38	S37	1A	1K	1M	1N
39	S38	1H	1J	1P	1D
40	S39	1F	1G	1Q	1E
41	COM0	▲			
42	COM1		▲		
43	COM2			▲	
44	COM3				▲

Dimensions

LCD

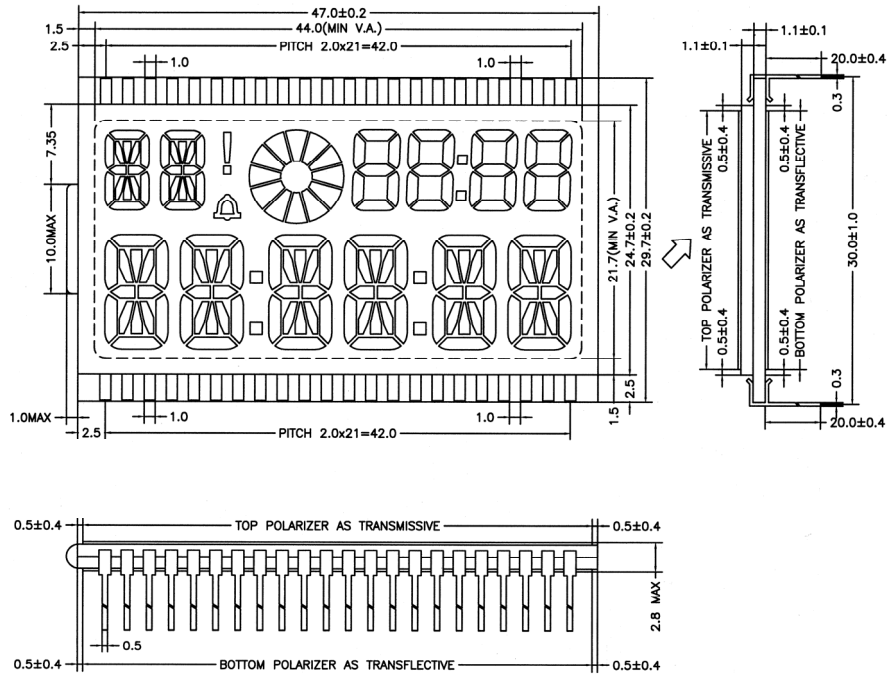

Figure 4 - LCD Dimensions (in millimeters)

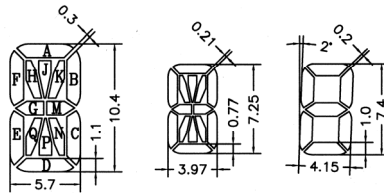

Figure 5 - Character Dimensions (in millimeters)

Backlight

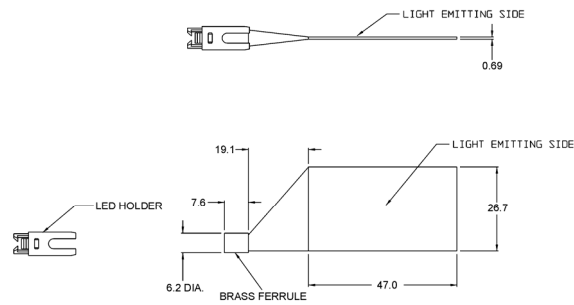

Figure 6 - Backlight Panel Dimensions (in millimeters)

Electro-Optical Characteristics

LCD

The SynchroChron LCD is optimized for viewing when the display is positioned slightly above or angled slightly away from the viewer.

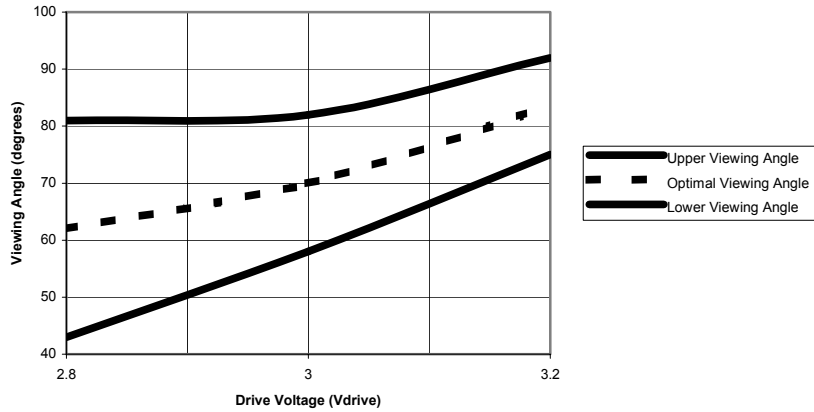

Figure 7 – LCD Viewing Angle vs Drive Voltage

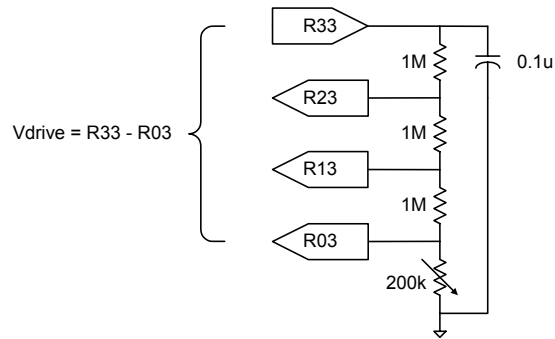

Figure 8 - Typical MSP430 LCD Bias Circuit

Backlight

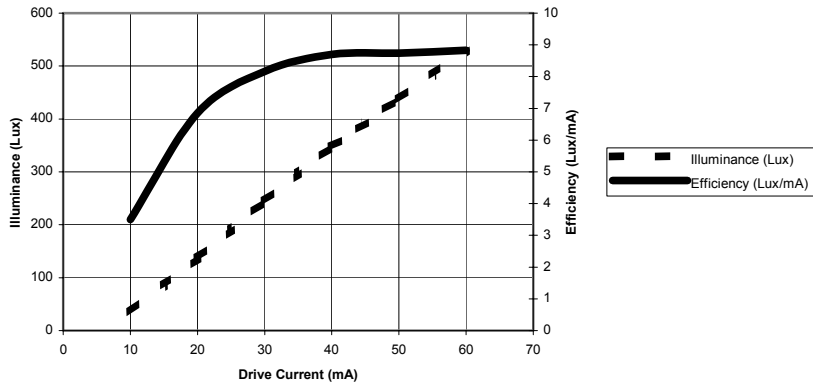

Figure 9 - Backlight Illuminance (at panel surface) vs Drive Current

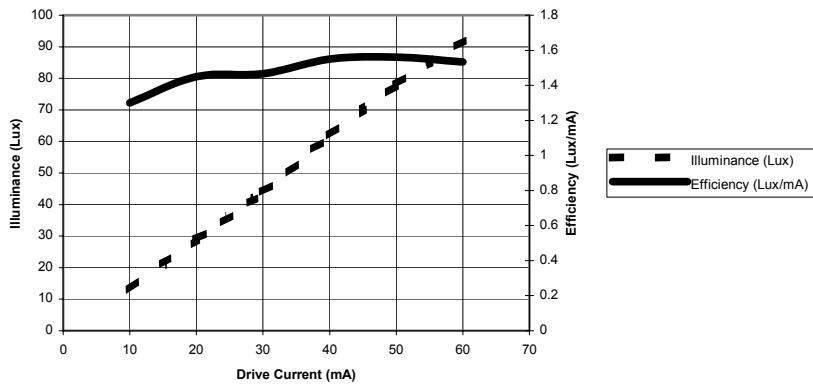

Figure 10 - Backlight Illuminance (at LCD surface) vs Drive Current

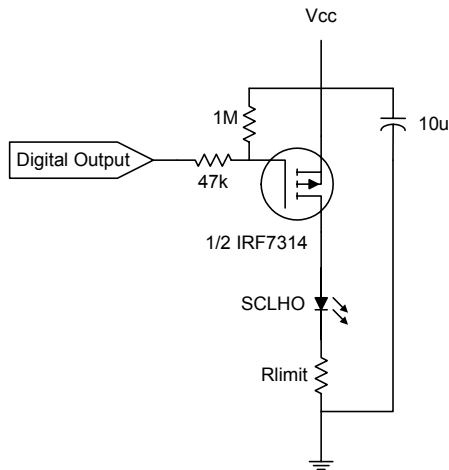

Figure 11 - Typical MSP430 Backlight LED Drive Circuit

Support

All support documentation and firmware for the SynchroChron LCD can be downloaded from <http://synchro.com/downloads.html>.

LCD Driver

Source code for an MSP430 LCD driver library is available. The driver provides character- and integer-based interfaces for writing to the SynchroChron LCD. The driver incorporates a 96 character font that includes upper and lower-case letters, numbers and punctuation characters. The driver supports steady and flashing characters and icons. The driver is easily modified to support any wiring arrangement between the MCU and LCD. The driver is written in C, using the Imagecraft ICC430 V7.06 compiler, but can be easily ported to other compilers and microcontrollers. See `firmware\lcd\readme.html` for a description of the driver files. See `firmware\lcd\lcd.c` for details of the driver functions. See the demonstration program for an example of how to use the LCD driver library.

The driver can be modified to support any LCD wiring configuration. Simply modify `firmware\lcd\lcd_wiring.h` to reflect the new wiring configuration.

When compiled using ImageCraft ICC430, by default the driver uses the `assert()` macro to trap illegal parameters. When `assert()` fails, it displays an error message on the LCD and halts the program. To disable this feature, recompile the library with `NDEBUG` defined.

Table 2 - LCD Driver Function Summary

Control	
LcdInit()	Initialize & energize LCD controller
LcdOn()	Turn on LCD timing generator & drive voltage
LcdOff()	Turn off LCD timing generator & drive voltage
LcdClear()	Clear entire display
LcdFlashSuppress(duration)	Stop flashing temporarily
LcdFlashTimer()	Flash timer handler
LcdScrollTimer()	Scroll timer handler
LcdIsScrolling()	Indicates state of scrolling activity
Display	
LcdShowSegs(segs, area, pos, flash)	Control segments in single cell
LcdShowChar(c, area, pos, flash)	Display a single ASCII character
LcdShowStr(s, area, pos, flash)	Display a string
LcdShowScroll(s)	Display a scrolling string in primary area
LcdShowUDec2(value, area, pos, lead_zero, flash)	Display a two-digit unsigned decimal integer
LcdShowUDec4(value, area, pos, lead_zero, flash)	Display a four-digit unsigned decimal integer
LcdShowDialCW(mask_ptr, flash)	Display dial segments, rotate clockwise
LcdShowDialCCW(mask_ptr, flash)	Display dial segments, rotate counter-clockwise
LcdShowError(mode_ptr, str_ptr, num)	Display error message & halt execution
Stdio	
putchar(c);	Stdio stream interface to LCD

Table 3 – LCD Driver Alphanumeric Font

	0	1	2	3	4	5	6	7	8	9			
	0	1	2	3	4	5	6	7	8	9			
A	B	C	D	E	F	G	H	I	J	K	L	M	
R	B	C	D	E	F	G	H	I	J	K	L	M	
N	O	P	Q	R	S	T	U	V	W	X	Y	Z	
N	O	P	Q	R	S	T	U	V	W	X	Y	Z	
a	b	c	d	e	f	g	h	i	j	k	l	m	
a	b	c	d	e	f	g	h	i	j	k	l	m	
n	o	p	q	r	s	t	u	v	w	x	y	z	
n	o	p	q	r	s	t	u	v	w	x	y	z	
"	\$	%	&	'	()	*	+	,	-	/	<	
"	\$	%	&	'	()	*	+	,	-	/	<	
=	>	?	@	[\]	^	_	`	{		}	~
=	>	?	@	[\]	^	_	`	{		}	~

Demonstration Program

Source code and a hex image of an MSP430 demonstration program is available to demonstrate many features of the SynchroChron LCD and driver. The demonstration program is designed to run on a modified Softbaugh ES449 evaluation board. The demonstration program is written in C, using the Imagecraft ICC430 compiler.

Evaluation Board

The SynchroChron LCD can be demonstrated on a modified Softbaugh ES449 evaluation board. The board can be purchased from the Softbaugh website at <http://softbaugh.com>.

To modify the ES449 board to support the SynchroChron LCD, follow these steps:

1. Remove the original 48-pin LCD, labeled LCD1.
2. Install the SynchroChron LCD in the leftmost 44 holes of LCD1. You will have to bend the leads in slightly as the SynchroChron LCD is slightly wider than the original LCD.
3. Using shorting blocks, jumper these pairs of pins on J23: 2-3, 5-6, 8-9 & 16-17.
4. Using jumper wire, jumper these pairs of pins on LCD1: 23-39 & 24-38. These are the LCD1 pin numbers, not the SynchroChron LCD pin numbers.

Table 4 - Modified ES449 board wiring configuration

MSP430F449 MCU pins		SynchroChron LCD pins		MSP430F449 MCU pins		SynchroChron LCD pins	
number	name	number	name	number	name	number	name
52	COM0	41	COM0	30	S18	20	S19
53	COM1	42	COM1	31	S19	19	S18
54	COM2	43	COM2	32	S20	18	S17
55	COM3	44	COM3	33	S21	17	S16
12	S0	34	S33	34	S22	16	S15
13	S1	38	S37	35	S23	15	S14
14	S2	32	S31	36	S24	14	S13
15	S3	31	S30	37	S25	13	S12
16	S4	23	S22	38	S26	12	S11
17	S5	24	S23	39	S27	11	S10
18	S6	25	S24	40	S28	10	S9
19	S7	26	S25	41	S29	9	S8
20	S8	27	S26	42	S30	8	S7
21	S9	28	S27	43	S31	7	S6
22	S10	29	S28	44	S32	6	S5
23	S11	30	S29	45	S33	5	S4
24	S12	33	S32	46	S34	4	S3
25	S13	36	S35	47	S35	3	S2
26	S14	37	S36	48	S36	2	S1
27	S15	35	S34	49	S37	1	S0
28	S16	22	S21	50	S38	40	S39
29	S17	21	S20	51	S39	39	S38

TrueType Font

A TrueType font representing the 14-segment alphanumeric font used in the driver is available. This font is useful for documenting applications that use the SynchroChron LCD. The SynchroChronLCD font is used in Table 3 above. The file is SynchroChronLCD.TTF.

Most characters in the font are used to show 14-segment alphanumeric display characters. However some punctuation marks are based on other parts of the display. The exclamation mark “!” is used to show the alarm icon. The colon “:”, period “.” and pound sign “#” are used to show the punctuation marks. The period shows the lower segment, the pound shows the upper segment and the colon shows both.